

# 38 Distribution networks

- A **corporate ladder** network that combines 4 identical loads  $Z_L$  into a single equivalent input impedance  $Z_L$  is shown in the margin.
- In this network 6 different quarter-wave transformers with arbitrary but identical characteristic impedances  $Z_o$  are utilized.

You should be able to compute the load voltages  $V_L$  in the network in terms of input voltage  $V_{in}$  applied across the input port by using the current-forcing formula for the quarter-wave transformer introduced earlier on.

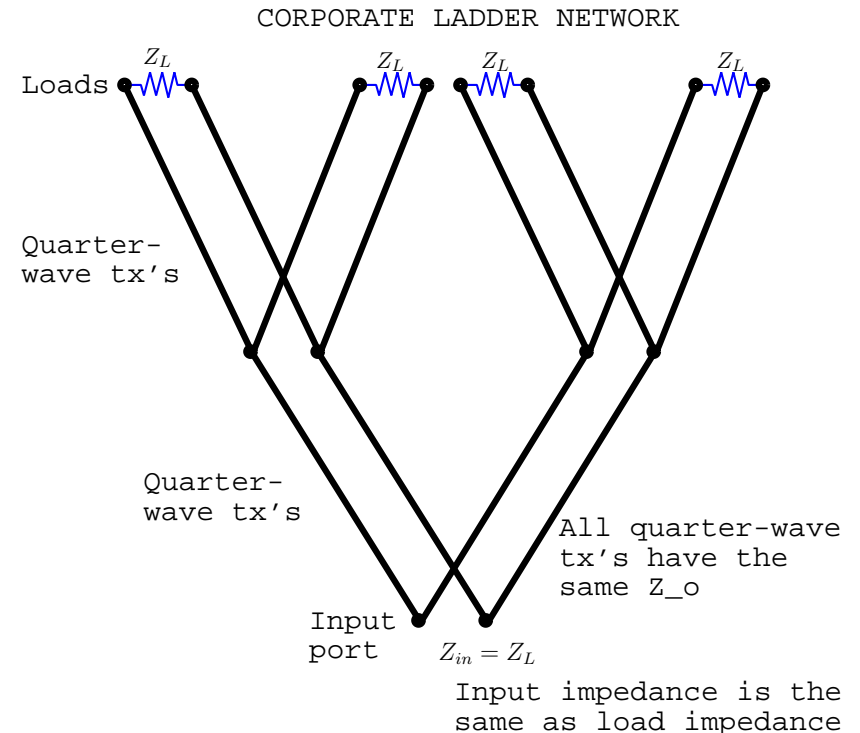

By symmetry, the loads absorb equal avg power, a quarter of the input power each.

- If, in a **corporate ladder** network,  $Z_L = Z_o$ , then TL segment lengths connected to each  $Z_L$  can be varied at will without affecting the input impedance  $Z_L = Z_o$  (why?).
- Allowing variable length TL's connected to each  $Z_L$  makes it possible to adjust and vary the phase of the voltage and current of each  $Z_L$  — this is useful, for instance, in feeding phased antenna arrays ( $Z_L$  represents an antenna load) to achieve steerable radiation patterns.

- A **hybrid combiner** network shown in the margin can be used to *excite* two identical TL loads  $R$  (e.g., antenna arrays impedance matched to have input impedances  $R$ ) with independent signal generators  $V_A$  and  $V_B$  having equal internal resistances  $R$  matched to the load resistance.

- The hybrid “rat-race” combiner is built with 6 quarter-wave transformers of identical

$$Z_o = \sqrt{2}R,$$

in which case the generators  $V_A$  and  $V_B$  see impedance-matched loads (at the hybrid inputs where they are connected) and produce load voltages proportional to  $V_A \pm V_B$  as shown in the diagram.

- Generators A and B with open ckt voltages  $V_A$  and  $V_B$  are *isolated* from one another’s influence because of “destructive interference” between the two paths from each generator to the other one (two paths have a  $\frac{\lambda}{2}$  length difference).
- This very special situation allows one to calculate the various terminal voltages on the hybrid due to  $V_A$  and  $V_B$  one-at-a-time as if loads  $R$  were isolated from generator-B and -A (by “virtual shorts” existing across generator terminals when  $V_B$  and  $V_A$  are suppressed) in turns, and then superpose the results.

HYBRID COMBINER --- SUM and DIFFERENCE OF ISOLATED GENERATOR SIGNALS  $V_A$  AND  $V_B$  ARE APPLIED TO LOADS  $R$

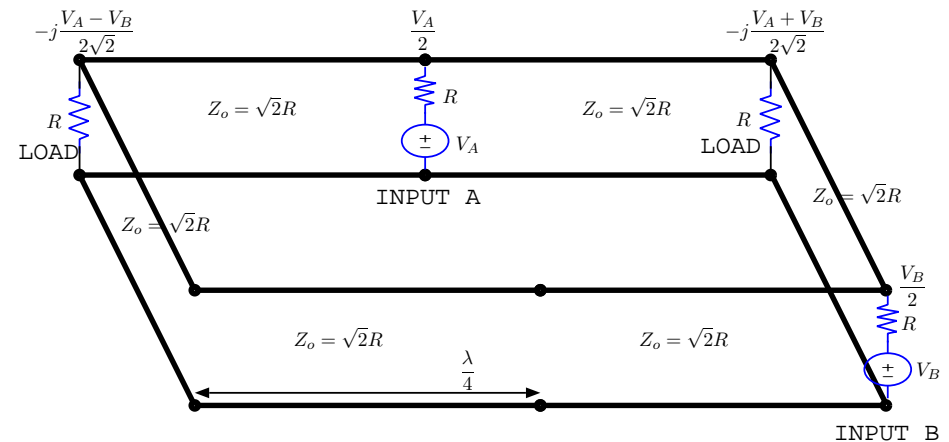

- Terminal voltages obtained with that procedure (those shown on the diagram) turn out to be valid when both generators are active as can easily be checked for self-consistency by using the current-forcing equations introduced earlier. For instance, the total current into generator-A terminal (flowing from both sides) is

$$I_A = -\frac{j}{R\sqrt{2}}\left(-j\frac{V_A - V_B}{2\sqrt{2}}\right) - \frac{j}{R\sqrt{2}}\left(-j\frac{V_A + V_B}{2\sqrt{2}}\right) = -\frac{V_A}{2R},$$

and hence the voltage drop from the same terminal to the ground is

$$I_A R + V_A = -\frac{V_A}{2R}R + V_A = \frac{V_A}{2}$$

as marked explicitly on the diagram. All self-consistency tests that can be applied with the given expressions are passed, and so the results given are valid.

- The input and output ports of a hybrid combiner can be swapped while still maintaining the properties of the hybrid — namely, input impedance  $R$ , and output signals the sum and difference of generator voltages.

